

LEADER[®]

● *Fighting for performance*



FIRE EXTINGUISHING

FIREFIGHTING NOZZLES AND MONITORS

AUTOMATIC NOZZLES | SELECTABLE FLOW | FOAM NOZZLES | PORTABLE MONITORS



CONTENTS
NOZZLES AND
MONITORS
FOR USE IN
FIREFIGHTING
AND INDUSTRIAL
OPERATIONS

PORTABLE MONITORS

P. 30 ■



WHAT MAKES LEADER FLOW DIFFERENT

P. 4 ■

INNOVATIONS

P. 6 ■

FIRE NOZZLES

P. 8 ■

- Selectable flow P. 10
- Automatic P. 14
- Trigger P. 18
- Accessories P. 26

PORTABLE MONITORS

P. 30 ■

- PARTNER 3000 L/MIN P. 32
- VECTOR 5000 L/MIN P. 36
- Accessories P. 40

LEADER FLOW OVERVIEW

P. 44 ■

LEADER SAS

P. 46 ■



WHAT MAKES LEADER FLOW DIFFERENT

FRENCH FAB: MADE IN NORMANDY



LEADER FLOW: An innovative range of nozzles and monitors: designed, assembled and tested in Normandy.

Aviation-standard machining, high-quality materials and inspection for the firefighting industry.

LEADER NOZZLES ARE AVAILABLE IN 3 SIZES:

■ **Compact** up to 400 l/min @ 6 bar ▶

■ **Regular** up to 600 l/min @ 7 bar ▶

■ **Large** up to 1000 l/min @ 6 bar ▶



MACHINED TEETH



LEADER has chosen to produce its Compact and Regular nozzles with machined teeth which offer better performance than rubber moulded teeth:

- Better quality protective spray jet.
- Improved distribution of fine droplets produced with the attack jet to absorb maximum energy.

OUR PRIORITY: FIREFIGHTER SAFETY

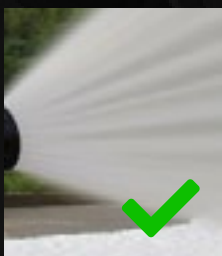

■ SLIDE VALVE NOZZLES FOR OPTIMUM JET QUALITY.

To work safely and efficiently, a firefighter needs a nozzle offering optimum jet quality. LEADER decided to design a large part of its nozzle range using a slide valve.

Unlike a ball valve which distorts the jet even making it unusable at small opening, there are many benefits to a slide valve, including:

- Limited turbulence regardless of the opening position of the flow handle.
- Easy to open the nozzle, particularly at high pressure.
- Reduced water hammer due to more gradual closing.
- Jet formed more quickly, so increased efficiency.

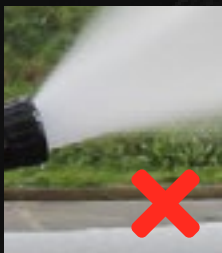

Whether automatic type (FLOWMATIC) or with selectable type (MULTIFLOW), LEADERFLOW nozzles in Compact and Regular sizes are all equipped with slide valves.



■ NOZZLES AND MONITORS WITH A VERY WIDE SPRAY JET FOR EFFECTIVE PROTECTION

To ensure maximum protection, the heads of LEADER nozzles and monitors are studied and designed:

- to obtain a very wide protective spray jet
- to create a wide water curtain and ensure effective protection against the fire spreading.



■ SAFETY VALVES FOR MONITORS

All PARTNER 2 and VECTOR 2 monitors are equipped with an anti-slip and anti-lifting safety valve.

After triggering the safety valve, the LEADER PARTNER and VECTOR monitors maintain a minimum sufficient flow rate to keep firefighters safe.

This valve-controlled partial closure is sufficient to stabilise the monitor and reduce water hammer to protect the hoses.



LEADER FLOW INNOVATIONS

TRIGGERFLOW: TRIGGER NOZZLE



■ A NEW CONCEPT:

A highly intuitive and more user-friendly trigger nozzle. Complete control of the nozzle without needing to move your hands.

One hand holds the nozzle and controls the flow rate with the fingers, the other hand manages the shape of the jet and easily guides movements generated by opening and closing the nozzle. The nozzles are available in the different FLOWMATIC and MULTIFLOW variants.

■ INTUITIVE USE

- Gradual opening and closing of the slide valve using a large trigger.
- Instant response for perfect control of the amount of water used.
- Hands are kept in a natural position, which makes it easier to control the nozzle and its movements.

■ SAFETY

- Hands and trigger protected with a large removable trigger guard.
- Nozzle naturally closes if it is dropped during use (if not locked).
- Anti-freeze position for low water flow during very cold conditions.

■ PERFORMANCE: TEST IT!

- Ideal for Pulsing thanks to its slide valve.
- Limited water hammer.
- Quarter-turn adjustment from straight jet to protective spray.
- Powerful full cone spray for smothering flames.
- 120° angle for the protective spray jet.
- Locking system to lock the nozzle in full opening position.

THE NEW COMPOSITE MATERIAL FOR NOZZLES AND INDUCTORS.

Always looking to make progress, LEADER has decided to include composite material parts in its firefighting equipment design which offers equal or greater qualities than usual materials.

■ COMPOSITE:

- ▶ A composite is a material made of:
 - a reinforcement (in this case, fibreglass) which provides most of the mechanical properties,
 - and a matrix which acts as a binder.
- ▶ It replaces metal alloys.
- ▶ Composite is already used for various applications: car, aviation and space industries, weapons, etc.

■ *FiberTech*® THE COMPOSITE USED IN OUR EQUIPMENT:

- ▶ Fibreglass-reinforced high-performance polymer-based composite material known for:
 - Excellent strength and exceptional rigidity
 - Dimensional stability and distortion resistance
 - Good resistance to chemical agents
 - Excellent impact resistance
 - Resistance to high temperatures
 - Good electrical insulation

■ THE COMPOSITE TACKLES THE CHALLENGE FACING ALUMINUM AND BRONZE!

- ▶ Far lighter compared to brass.
- ▶ Lighter compared to aluminum alloy.
- ▶ Mechanical strength and durability equivalent to aluminum alloy.
- ▶ Corrosion resistance greater than aluminum alloy and brass:
 - in a salt-water environment
 - during use with foam concentrates.
- ▶ Resistance to chemical products equivalent to aluminum alloy.
- ▶ Heat resistance: No mass distortion at high heats like with aluminum.
- ▶ Heat insulation: The material naturally insulates the user from the cold.
- ▶ Electrical insulation: Better protection for the firefighter.



THE RANGE OF LEADER FLOW FIRE NOZZLES

INNOVATIVE PRODUCTS FOR
MAXIMUM EFFICIENCY DURING
FIREFIGHTING OPERATIONS.

LEADER FLOW : ROBUST AND EFFICIENT

- **MULTIFLOW:** selectable flow rate,
- **FLOWMATIC:** regulated pressure or automatic,
- **ONEFLOW:** fixed flow rate,
- **Special:** for gas cooling, forest fires, etc.

LEADER FLOW nozzles are designed to be efficient and reliable in all circumstances, including the most extreme operations which firefighters must tackle.



MULTIFLOW: SELECTABLE FLOW RATE

P. 10

- ✓ Highly flexible use
- ✓ Robust
- ✓ Compliant with EN15182-2



FLOWMATIC: AUTOMATIC

P. 14

- ✓ Easy to use
- ✓ Ideal for pulsing
- ✓ With or without flush selector ring



TRIGGERFLOW: WITH TRIGGER

P. 18

- ✓ Instinctive use
- ✓ Ideal for pulsing
- ✓ Automatic or selectable



OTHER NOZZLES

P. 22

- ✓ ONEFLOW: Fixed flow rate
- ✓ TWIN-ACTION: Water and foam
- ✓ For gas cooling



ACCESSORIES AND VARIANTS

P. 26

- ✓ Multi-expansion foam adapter
- ✓ Identification handle, turbine, etc.



MULTIFLOW: SELECTABLE FLOW NOZZLES

FLEXIBLE AND ROBUST

LEADER offers a range of selectable flow nozzles with a range from 20 to 1000 l/min. MULTIFLOW, type 3 nozzles, comply with EN15182-2.

Thanks to the large flow selection ring, the user can choose the flow rate. They can adjust the handle whilst maintaining a perfect jet, without causing turbulence, thanks to the nozzle's slide valve.



MULTIFLOW 500
Aluminum regular



MULTIFLOW 500
Fibertech regular

FEATURES AND BENEFITS

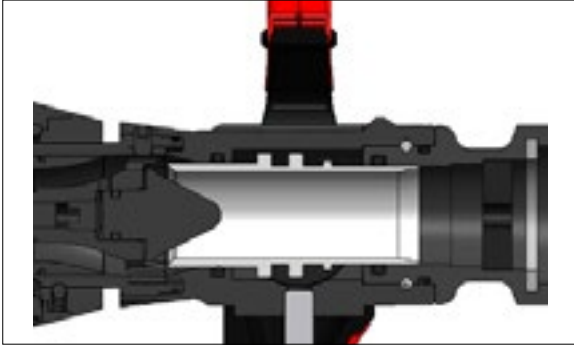

Slide valve for Compact and Regular nozzles:

Minimises water hammer and allows gradual opening/closing with the handle. Ideal for pulsing.



Polyurethane bumper:

For improved resistance to hydrocarbons and chemical products.



User-friendly:

A large handle for superior handling. Ideal for pulsing.



Large tactile pointer:

Large spray jet tactile marker, with a bright colour and grip texture.



Fibertech body for Regular nozzles:

A composite material for a lower weight and greater corrosion resistance.



Very wide spray jet:

To keep the firefighter as safe as possible when needed.

MULTIFLOW



MULTIFLOW 150 **MULTIFLOW 235** **MULTIFLOW 400** **MULTIFLOW 40 GPM** **MULTIFLOW 60 GPM** **MULTIFLOW 125 GPM**

REFERENCE

CMFA-0530-LIR CMFA-0531-LIR CMFA-0532-EIR CMFA-0533-1IR CMFA-0534-RIR CMFA-0535-RIR

PERFORMANCES

Flow rates	20 - 40 - 100-150 l/min @ 6 bar	40 - 100 - 150 -235 l/min @ 6 bar	70 - 130 - 230 - 400 l/min @ 6 bar	5 - 10 - 24 - 40 GPM @ 100PSI	10 - 24 - 40 - 60 GPM @ 100PSI	30 - 60 - 95 -125 GPM @ 100PSI
High-pressure 40 bar / 500 PSI	■	■	■	■	■	■
Stainless steel slide valve	■	■	■	■	■	■
From straight jet to max. protection in 90° (1/4 turn)	■	■	■	■	■	■

FEATURES (without coupling)

Weight	1.75 kg	1.75 kg	1.85 kg	1.75 kg	1.75 kg	1.75 kg
Dimensions	L. 29 x w. 12 x h. 23 cm*	L. 29 x w. 12 x h. 23 cm*	L. 31.5 x w. 12 x h. 23 cm	L. 29 x w. 12 x h. 23 cm*	L. 29 x w. 12 x h. 23 cm*	L. 29 x w. 12 x h. 23 cm
Format (C, R or L)	C	C	C	C	C	C
Material: hard anodised aluminum	■	■	■	■	■	■
Machined teeth	■	■	■	■	■	■
Std colour	Red	Red	Red	Red	Red	Red
Thread	BSP	BSP	BSP	NH	NH	NH
Std inlets	1" F	1" F	2" M	1" F	1.5" F	1.5" F

OPTIONS AND ACCESSORIES

TRIGGERFLOW *	<input type="checkbox"/>	<input type="checkbox"/>	<input type="checkbox"/>	<input type="checkbox"/>	<input type="checkbox"/>	<input type="checkbox"/>
Fibertech body	-	-	-	-	-	-
Stainless steel turbine	<input type="checkbox"/>	<input type="checkbox"/>	<input type="checkbox"/>	<input type="checkbox"/>	<input type="checkbox"/>	<input type="checkbox"/>
Different coloured handles	<input type="checkbox"/>	<input type="checkbox"/>	<input type="checkbox"/>	<input type="checkbox"/>	<input type="checkbox"/>	<input type="checkbox"/>
Multi-expansion foam adapter	●	●	●	●	●	●
Other inlets	<input type="checkbox"/> 2" BSP M <input type="checkbox"/> GFR 20 F <input type="checkbox"/> NH	<input type="checkbox"/> 2" BSP M <input type="checkbox"/> GFR 20 F <input type="checkbox"/> NH	<input type="checkbox"/> 1.5" BSP F <input type="checkbox"/> NH	<input type="checkbox"/> BSP	<input type="checkbox"/> BSP	<input type="checkbox"/> 1.5" NPSH F <input type="checkbox"/> BSP
International couplings	☎	☎	☎	☎	☎	☎

WARRANTY

Parts and labour	5 years	5 years	5 years	5 years	5 years	5 years
-------------------------	---------	---------	---------	---------	---------	---------

KEY

- As standard
- Option (variant) to be indicated when ordering
- Accessory which can be supplied later
- Not applicable
- ☎ On request

- C - Compact Size
- R - Regular Size
- L - Large Size
- M - Male
- F - Female



*** TRIGGERFLOW:** A new concept for a more intuitive and user-friendly nozzle. One hand holds the nozzle and controls the flow rate with the fingers, and the other hand manages the jet pattern and withstands recoil force if necessary. For more information see page 18.



MULTIFLOW 400 **MULTIFLOW 500** **MULTIFLOW 150 GPM** **MULTIFLOW 1000** **MULTIFLOW 200 GPM** **MULTIFLOW 250 GPM**

REFERENCE

RMFC-0508-EIR

RMFA-0501-MIR

RMFA-0504-RIR

LMFA-0517-OIR

LMFA-0519-SIR

LMFA-0518-SIR

PERFORMANCES**Flow rates**70 - 130 - 230 -
400 l/min
@ 6 bar100 - 250 - 350 -
500 l/min
@ 6 bar60 - 95 - 125 -
150 GPM
@ 100PSI300 - 500 - 750 -
1000 l/min
@ 6 bar95 - 125 - 150 -
200 GPM
@ 100PSI125 - 150 -
200 - 250 GPM
@ 100PSI**High-pressure 40 bar / 500 PSI**

-

-

-

-

-

-

Stainless steel slide valve

■

■

■

Ball valve

Ball valve

Ball valve

**From straight jet to max.
protection in 90° (1/4 turn)**

■

■

■

-

-

-

**FEATURES
(without coupling)****Weight**

2.15 kg

2.4 kg

2.4 kg

3.35 kg

3.2 kg

3.35 kg

DimensionsL. 32 x w. 13 x h.
25 cmL. 30 x w. 13 x h.
25 cmL. 30 x w. 13 x h.
25 cmL. 35 x w. 13 x h.
26 cmL. 35 x w. 13 x h.
26 cmL. 35 x w. 13 x
h. 26 cm**Format (C, R or L)**

R

R

R

L

L

L

**Material: hard anodised
aluminum**

Fibertech

■

■

■

■

■

Machined teeth

■

■

■

Moulded

Moulded

Moulded

Std colour

Red

Red

Red

Red

Red

Red

Thread

BSP

BSP

NH

BSP

NH

NH

Std inlets

2" M

1.5" F

1.5" F

2.5" F

2.5" F

2.5" F

**OPTIONS
AND ACCESSORIES****TRIGGERFLOW ***

□

□

□

-

-

-

Fibertech body

■

□ = 2.15 kg

□ = 2.15 kg

-

-

-

Stainless steel turbine

□

□

□

-

-

-

**Different coloured
handles**

□

□

□

□

□

□

**Multi-expansion
foam adapter**

●

●

●

●

●

●

Other inlets□ 1.5" BSP F
□ NH□ 2" BSP M
□ NH□ 1.5" NPSH F
□ BSP

□ NH

□ 1.5" NH F
□ BSP

□ BSP

International couplings

☎

☎

☎

☎

☎

☎

WARRANTY**Parts and labour**

5 years

5 years

5 years

5 years

5 years

5 years

KEY

■ As standard

□ Option (variant) to be indicated when ordering

● Accessory which can be supplied later

- Not applicable

☎ On request

C - Compact Size

R - Regular Size

L - Large Size

M - Male

F - Female

*** TRIGGERFLOW:** A new concept for a more intuitive and user-friendly nozzle

One hand holds the nozzle and controls the flow rate with the fingers, and the other hand manages the jet pattern and withstands recoil force if necessary. For more information see page 18.



FLOWMATIC: AUTOMATIC NOZZLES

EASY TO USE AND ROBUST

LEADER offers a full range of automatic nozzles from 20 l/min to 1000 l/min. FLOWMATIC, type 4 nozzles, comply with EN15182-2.

More intuitive to adjust, the flow rate of an automatic nozzle is controlled just by using the large handle.

When the user operates the handle to reduce or increase the flow rate, FLOWMATIC adapts constantly to maintain the range of the jet:

- the automatic pressure regulation system acts as a spring to balance pressure variations and maintain constant pressure in the nozzle. As a pressure damper, it adjusts the nozzle output to maintain an efficient jet.
- the slide valve guarantees a perfect jet without turbulence.



FLOWMATIC 250
Compact aluminum



FLOWMATIC 500
Regular Fibertech

FEATURES AND BENEFITS

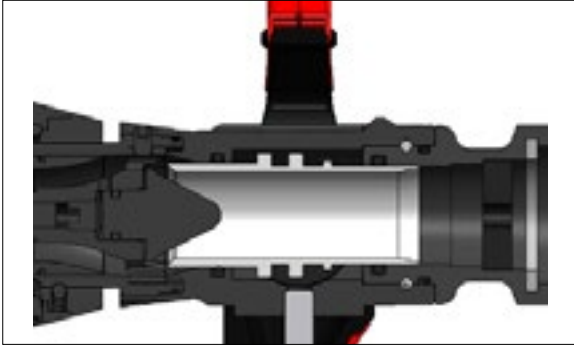

Slide valve for Compact and Regular nozzles:

Minimises water hammer and allows gradual opening/closing using the handle. Ideal for pulsing.

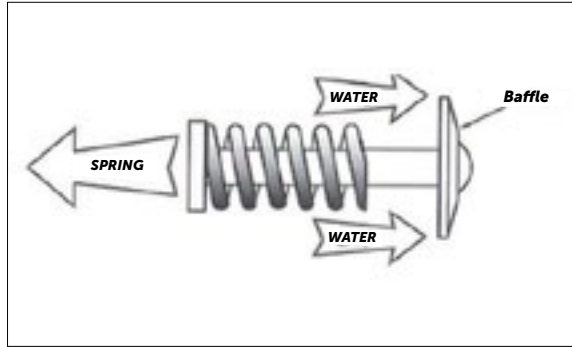

Pressure regulation system:

To maintain an optimised range despite pressure changes in water supply.

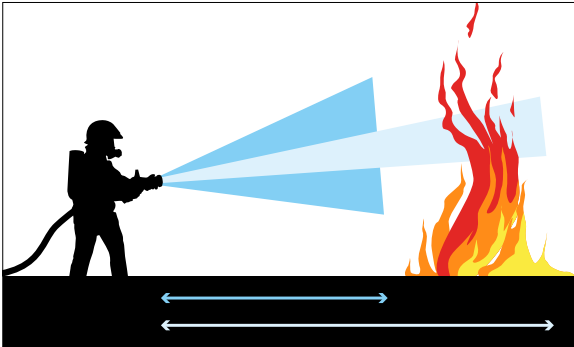

Two jet positions for attack:

In addition to straight, flashover and protective spray jets, FLOWMATIC Regular offers a second attack jet at a small angle (25 to 30°) which allows firefighters to work at a distance whilst staying safe.



Pulsing:

Effective from 2 bars with very fine droplets for improved heat absorption.



Fibertech body for Regular nozzles:

A composite material for a lower weight and greater corrosion resistance.



Very wide spray jet:

To keep the firefighter as safe as possible when needed.

FLOWMATIC



FLOWMATIC 150 **FLOWMATIC 250** **FLOWMATIC 400** **FLOWMATIC 400 AA** **FLOWMATIC 125 GPM**

REFERENCE

CFMA-0537-LIB CFMA-0539-LIB CFMA-0541-EIB CFMD-0541-EIR CFMA-0543-RIB

PERFORMANCES

Flow rates from 2 to 6 bar	0 to 150 l/min	0 to 250 l/min	0 to 400 l/min	0 to 400 l/min	0 to 125 GPM @ 100 PSI
Effective pulsing at +2 bar	■	■	■	■	■
High-pressure 40 bar / 500 PSI	■	■	■	■	■
Stainless steel slide valve	■	■	■	■	■
Double Click Flash Over	-	-	-	-	-
From straight jet to max. Protection in 90° (1/4 turn)	■	■	■	■	■

FEATURES (without coupling)

Weight	1.65 kg	1.65 kg	1.75 kg	1.85 kg	1.75 kg
Dimensions	L. 25 x w. 12 x h. 23 cm	L. 25 x w. 12 x h. 23 cm	L. 29.5 x w. 12 x h. 23 cm	L. 29.5 x w. 12 x h. 23 cm	L. 29.5 x w. 12 x h. 23 cm
Format (C, R or L)	C	C	C	C	C
Material: hard anodised aluminum	■	■	■	■	■
Machined teeth	■	■	■	■	■
Std colour	Blue	Blue	Blue	Red	Blue
Thread	BSP	BSP	BSP	BSP	NH
Std inlet	1" F	1" F	2" M	2" M	1.5" F

OPTIONS AND ACCESSORIES

TRIGGERFLOW *	<input type="checkbox"/>	<input type="checkbox"/>	<input type="checkbox"/>	-	<input type="checkbox"/>
Fibertech body	-	-	-	-	-
Flush selector ring	<input type="checkbox"/>	<input type="checkbox"/>	<input type="checkbox"/>	<input type="checkbox"/>	<input type="checkbox"/>
Stainless steel turbine	<input type="checkbox"/>	<input type="checkbox"/>	<input type="checkbox"/>	<input type="checkbox"/>	<input type="checkbox"/>
Different coloured handles	<input type="checkbox"/>	<input type="checkbox"/>	<input type="checkbox"/>	-	<input type="checkbox"/>
Multi-expansion foam adapter	●	●	●	●	●
AA flow limitation	<input type="checkbox"/>	<input type="checkbox"/>	<input type="checkbox"/>	■	●
Other inlets	<input type="checkbox"/> 2" BSP M <input type="checkbox"/> GFR 20 F	<input type="checkbox"/> 2" BSP M <input type="checkbox"/> GFR 20 F	<input type="checkbox"/> 1.5" BSP F	<input type="checkbox"/> 1.5" BSP F	<input type="checkbox"/> 1.5" NPSH F
International couplings	☎	☎	☎	☎	☎

WARRANTY

Parts and labour	5 years	5 years	5 years	5 years	5 years
-------------------------	---------	---------	---------	---------	---------

KEY

- As standard
- Option (variant) to be indicated when ordering
- Accessory which can be supplied later
- Not applicable
- ☎ On request

- C - Compact Size
- R - Regular Size
- L - Large Size
- M - Male
- F - Female



*** TRIGGERFLOW:** A new concept for a more intuitive and user-friendly nozzle. One hand holds the nozzle and controls the flow rate with the fingers, and the other hand manages the jet pattern and withstands recoil force if necessary. For more information see page 18.



REFERENCE	RFMA-0509-EIB	RFMA-0511-MIB	RFMA-0524-RIB	LFMA-0525-OIB	LFMA-0526-SIB	LFMA-0527-SIB
------------------	---------------	---------------	---------------	---------------	---------------	---------------

PERFORMANCES						
Flow rates from 2 to 6 bar	0 to 400 l/min	0 to 500 l/min	0 to 150 GPM @ 100PSI	0 to 1000 l/min	0 to 200 GPM @ 100 PSI	0 to 250 GPM @ 100 PSI
Effective pulsing at +2 bar	■	■	■	-	-	-
High-pressure 40 bar / 500 PSI	-	-	-	-	-	-
Stainless steel slide valve	■	■	■	Ball valve	Ball valve	Ball valve
Double Click Flash Over	■	■	■	-	-	-
From straight jet to max. Protection in 90° (1/4 turn)	■	■	■	-	-	-

FEATURES (without coupling)						
Weight	2.2 kg	2.2 kg	2.2 kg	3.2 kg	3.2 kg	3.2 kg
Dimensions	L. 27 x w. 13 x h. 25 cm	L. 26 x w. 13 x h. 25 cm	L. 26 x w. 13 x h. 25 cm	L. 33 x w. 13 x h. 26 cm	L. 33 x w. 13 x h. 26 cm	L. 33 x w. 13 x h. 26 cm
Format (C, R or L)	R	R	R	L	L	L
Material: hard anodised aluminum	■	■	■	■	■	■
Machined teeth	■	■	■	Moulded	Machined	Moulded
Std colour	Blue	Blue	Blue	Blue	Blue	Blue
Thread	BSP	BSP	NH	BSP	NH	NH
Inlet	2" M	1.5" F	1.5" F	2.5" F	2.5" F	2.5" F

OPTIONS AND ACCESSORIES						
TRIGGERFLOW *	□	□	□	-	-	-
Fibertech body	□ = 2 kg	□ = 2 kg	□ = 2 kg	-	-	-
Flush selector ring	-	-	-	■	■	■
Stainless steel turbine	□	□	□	-	-	-
Different coloured handles	□	□	□	□	□	□
Multi-expansion foam adapter	●	●	●	●	●	●
AA flow limitation						
Other inlets	□ 1.5" BSP F	□ 2" BSP M	□ 1.5" NPSH F	-	□ 1.5" NH F	-
International couplings	☎	☎	☎	☎	☎	☎

WARRANTY						
Parts and labour	5 years	5 years	5 years	5 years	5 years	5 years

KEY

- As standard
- Option (variant) to be indicated when ordering
- Accessory which can be supplied later
- Not applicable
- ☎ On request

- C - Compact Size
- R - Regular Size
- L - Large Size
- M - Male
- F - Female



*** TRIGGERFLOW:** A new concept for a more intuitive and user-friendly nozzle. One hand holds the nozzle and controls the flow rate with the fingers, and the other hand manages the jet pattern and withstands recoil force if necessary. For more information see page 18.



TRIGGERFLOW: TRIGGER NOZZLE

FLEXIBLE AND PRECISE

The TRIGGERFLOW FLOWMATIC automatic, (type 4) or TRIGGERFLOW MULTIFLOW selectable (type 3), comply with EN15182-2.

Ideal for pulsing:

One hand holds the nozzle and controls the flow rate with the fingers, and the other hand controls the jet pattern and helps with movement.

This simple procedure makes the TRIGGERFLOW totally instinctive to use. The TRIGGERFLOW can be used to precisely

apply the required amount of water.

The TRIGGERFLOW is supplied with water in line with the nozzle jet. This design helps absorb recoil force.

Safer:

The nozzle closes if it is dropped, which makes it safer during use, as well as when pressurised.

The TRIGGERFLOW trigger guard reduces the risk of impact against the firefighter's hand and avoids unwanted actuation on the trigger.



TRIGGERFLOW
with trigger guard



TRIGGERFLOW
without trigger guard

FEATURES AND BENEFITS



Instinctive use:

The trigger makes natural and instinctive to use. The nozzle closes naturally if it is dropped.



Effective pulsing:

Even at low pressure with the FLOWMATIC: very fine droplets for improved heat absorption.



Anti-freeze position:

To avoid ice forming in the hoses during operations in very cold conditions.



Slide valve:

Minimises water hammer and allows gradual opening/closing of the handle, even at high pressure.



Max flow rate lock:

Lock in max. flow rate position: this makes it easier for the operator during fires requiring max. flow rate for several minutes.



Trigger guard:

The removable trigger guard improves firefighter safety and ensures total control of the jet in the event of an impact.

MULTI-FLOW TRIGGERFLOW



**TRIGGERFLOW
150
MULTIFLOW**

**TRIGGERFLOW
235
MULTIFLOW**

**TRIGGERFLOW
400
MULTIFLOW**

**TRIGGERFLOW
500
MULTIFLOW**

**TRIGGERFLOW
150 GPM
MULTIFLOW**

REFERENCE

CMFG-1530-LIR

CMFG-1531-LIR

CMFG-1532-EIR

RMFG-1501-MIR

RMFG-1504-RIR

PERFORMANCES

Flow rates	20 - 40 - 100 - 150 l/min @ 6 bar	40 - 100 - 150 - 235 l/min @ 6 bar	70 - 130 - 230 - 400 l/min @ 6 bar	100 - 250 - 350 - 500 l/min @ 6 bar	60 - 95 - 125 - 150 GPM @ 100PSI
High-pressure 40 bar / 500 PSI	■	■	■	-	-
Stainless steel slide valve	■	■	■	■	■
Double Click Flash Over	-	-	-	-	-
From straight jet to max. Protection in 90° (1/4 turn)	■	■	■	■	■

FEATURES (without coupling)

Weight	2.3 kg	2.3 kg	2.4 kg	2.65 kg	2.65 kg
Dimensions	L. 35 x w. 9 x h.21 cm	L. 35 x w. 9 x h.21 cm	L. 38 x w. 9 x h.21 cm	L. 38 x w. 10 x h.22 cm	L. 38 x w. 10 x h.22 cm
Format (C, R or L)	C	C	C	R	R
Material: hard anodised aluminum	■	■	■	■	■
Machined teeth	■	■	■	■	■
Std colour Red	■	■	■	■	■
Thread	BSP	BSP	BSP	BSP	NH
Inlet	1" F	1" F	2" M	1.5" F	1.5" F

OPTIONS AND ACCESSORIES

Flush selector ring	<input type="checkbox"/>	<input type="checkbox"/>	<input type="checkbox"/>	-	-
Stainless steel turbine	<input type="checkbox"/>	<input type="checkbox"/>	<input type="checkbox"/>	<input type="checkbox"/>	<input type="checkbox"/>
Multi-expansion foam adapter	<input checked="" type="checkbox"/>	<input checked="" type="checkbox"/>	<input checked="" type="checkbox"/>	<input checked="" type="checkbox"/>	<input checked="" type="checkbox"/>
Other inlets	<input type="checkbox"/> 2" BSP M <input type="checkbox"/> GFR 20 F	<input type="checkbox"/> 2" BSP M <input type="checkbox"/> GFR 20 F	<input type="checkbox"/> 1.5" BSP F	<input type="checkbox"/> 2" BSP M	<input type="checkbox"/> 1.5" NPSH F
International couplings	<input checked="" type="checkbox"/>	<input checked="" type="checkbox"/>	<input checked="" type="checkbox"/>	<input checked="" type="checkbox"/>	<input checked="" type="checkbox"/>

WARRANTY

Parts and labour	5 years	5 years	5 years	5 years	5 years
-------------------------	---------	---------	---------	---------	---------

KEY

- As standard
- Option (variant) to be indicated when ordering
- Accessory which can be supplied later
- Not applicable
- ☎ On request

- C - Compact Size
- R - Regular Size
- M - Male
- F - Female

AUTOMATIC TRIGGERFLOW



TRIGGERFLOW 150 FLOWMATIC **TRIGGERFLOW 250 FLOWMATIC** **TRIGGERFLOW 400 FLOWMATIC** **TRIGGERFLOW 400 FLOWMATIC** **TRIGGERFLOW 500 FLOWMATIC** **TRIGGERFLOW 150 GPM FLOWMATIC**

REFERENCE

CFMG-1537-LIR CFMG-1539-LIR CFMG-1541-EIR RFMG-1509-EIR RFMG-1511-MIR RFMG-1524-RIR

PERFORMANCES

Flow rates from 2 to 6 bar	0 to 150 l/min	0 to 250 l/min	0 to 400 l/min	0 to 400 l/min	0 to 500 l/min	0 to 150 GPM @ 100 PSI
High-pressure 40 bar / 500 PSI	■	■	■	-	-	-
Stainless steel slide valve	■	■	■	■	■	■
Double Click Flash Over	-	-	-	■	■	■
From straight jet to max. Protection in 90° (1/4 turn)	■	■	■	■	■	■

FEATURES (without coupling)

Weight	2.2 kg	2.2 kg	2.3 kg	2.55 kg	2.45 kg	2.45 kg
Dimensions	L. 31 x w. 9 x h.21 cm	L. 31 x w. 9 x h.21 cm	L. 34 x w. 9 x h.21 cm	L. 35 x w. 10 x h.22 cm	L. 33 x w. 10 x h.22 cm	L. 33 x w. 10 x h.22 cm
Format (C, R or L)	C	C	C	R	R	R
Hard anodised aluminum	■	■	■	■	■	■
Machined teeth	■	■	■	■	■	■
Std colour Red	■	■	■	■	■	■
Thread	BSP	BSP	BSP	BSP	BSP	NH
Inlet	1" F	1" F	2" M	2" M	1.5" F	1.5" F

OPTIONS AND ACCESSORIES

Flush selector ring	□	□	□	-	-	-
Stainless steel turbine	□	□	□	□	□	□
Multi-expansion foam adapter	●	●	●	●	●	●
Other inlets	□ 2" BSP M □ GFR 20 F	□ 2" BSP M □ GFR 20 F	□ 1.5" BSP F □ 1.5" NH F (125GPM)	□ 1.5" BSP F	□ 2" BSP M	□ 1.5" NPSH F
International couplings	☎	☎	☎	☎	☎	☎

WARRANTY

Parts and labour	5 years	5 years	5 years	5 years	5 years	5 years
-------------------------	---------	---------	---------	---------	---------	---------

KEY

- As standard
- Option (variant) to be indicated when ordering
- Accessory which can be supplied later
- Not applicable
- ☎ On request

- C - Compact Size
- R - Regular Size
- M - Male
- F - Female



SPECIAL NOZZLES

FIXED FLOW RATE, SMOOTH BORE,
WATER/FOAM, GAS COOLING INJECTION...

Discover an offer which will meet the most specific requirements.

For fighting specific fires, LEADER engineers have developed several types of even better adapted nozzles: ONEFLOW, TWIN ACTION, full jet, gas cooling nozzle.

Each type has several models and different configurations to adapt to all constraints and uses: inerting fires in enclosed spaces, forest fires or any other type of indoor or outdoor operation.

LEADER regularly offers new products which meet the needs of firefighters, so please visit our website regularly to check our news.



*Full jet nozzle
with smooth bore*



ONEFLOW 500
Regular Aluminum

FEATURES AND BENEFITS



ONEFLOW:

A fixed flow rate slide valve nozzle to limit water hammer (with or without spinning teeth).



TWIN ACTION:

Adjustable flow nozzles with a built-in low-expansion foam generator.



Full jet nozzle body:

Large ball valve for use with smooth bores to limit pressure loss when fully open.

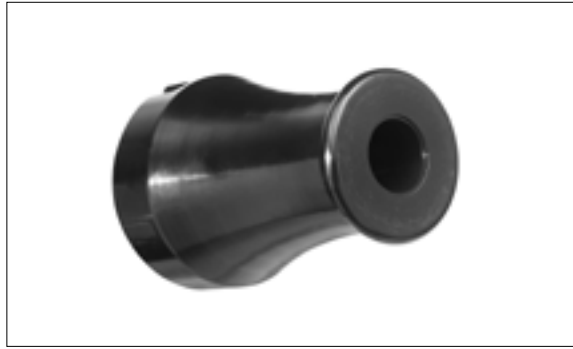

Smooth bore:

Compact and robust, these smooth bores provide a powerful jet with high impact.



Fibertech body for ONEFLOW and TWIN-ACTION:

Lower weight and increased corrosion resistance.



Gas cooling nozzle:

To extinguish a fire in an enclosed space (container, loft) from the outside when access conditions are difficult or hazardous for firefighters.

ONEFLOW, TWIN-ACTION AND SMOOTH BORE NOZZLE



ONEFLOW:

- Fixed-flow nozzle.
- Equipped with a slide valve.
- Hard anodised aluminum body.
- Also available in Fibertech.



SMOOTH BORE NOZZLE:

These compact and robust nozzles offer a powerful jet with high impact. They are made up of 2 key elements:

- The "body": stainless steel ball valve with a male NH 1.5" threaded outlet.
- The "Smooth bores": female NH 1.5", they are screwed onto the body outlet.



TWIN-ACTION:

- Multifunctional water/foam nozzle.
- Adjustable flow rate nozzle of 80 and 250 l/min with built-in low-expansion (10) foam function.

KEY

- As standard
- Option (variant) to be indicated when ordering
- Option which can be supplied later
- Not applicable
- ☎ On request



	ONEFLOW 500	ONEFLOW 150G	TWIN ACTION	FULL JET NOZZLE BODY	3/4" FULL JET TIP	16/16" FULL JET TIP	
REFERENCE	ROFA-0528-MIR	ROFA-0529-RIR	LTC-009-MI	LSBA- 0502-R6R	SBA-60-RI	SBA-61-RI	
PERFORMANCES	Fixed flow	Fixed flow	Water/foam	ball valve	tapered barrel	tapered barrel	
Flow rates	500 l/min @ 6 bar	150 GPM @ 100 PSI	80 and 250 l/min @ 6 bar	-	3/4" = 19MM	15/16" = 24MM	
Stainless steel slide valve	■	■	-	-	-	-	
Stainless steel ball valve	-	-	■	■	-	-	
FEATURES (without coupling)	Weight	2.2 kg	2.2 kg	1.5 kg	1.5 kg	0.5 kg	0.5 kg
Dimensions	L. 26 x w. 13 x h. 25 cm	L. 26 x w. 13 x h. 25 cm	L. 22 x w. 13 x h. 27 cm	L. 19 x w. 13 x h. 25 cm	L.10.5 x diam. 7.5 cm	L.10.5 x diam. 7.5 cm	
Hard anodised aluminum	■	■	Fibertech	■	■	■	
Machined teeth	■	■	-	-	-	-	
Std colour	Red	Red	Yellow	Red			
Thread	1.5" BSP F	1.5" NH F	1.5" BSP F	Inlet: 1.5" NH F Outlet: 1.5" NH M	1.5" NH F	1.5" NH F	
OPTIONS AND ACCESSORIES	Stainless steel turbine	□	□	-	-	-	
Different coloured handles	□	□	-	□	-	-	
Multi-expansion foam adapter	●	●	■ Low expansion	-	-	-	
Other inlets	□ 2" BSP M	□ 1.5" NPSH F	□ 2" BSP M □ 1.5" NH F	□ 1.5" NH F □ 1.5" BSP F	□ 1.5" NPSH F	□ 1.5" NPSH F	
International couplings	☎	☎	☎	☎	-	-	
WARRANTY	Parts and labour	5 years	5 years	5 years	5 years	2 years	2 years

REFERENCE

PERFORMANCES

Type

Fixed flow

Fixed flow

Water/foam

ball valve

tapered barrel

tapered barrel

Flow rates

500 l/min @ 6 bar

150 GPM @ 100 PSI

80 and 250 l/min @ 6 bar

-

3/4" = 19MM

15/16" = 24MM

Stainless steel slide valve

■

■

-

-

-

-

Stainless steel ball valve

-

-

■

■

-

-

FEATURES

(without coupling)

Weight

2.2 kg

2.2 kg

1.5 kg

1.5 kg

0.5 kg

0.5 kg

Dimensions

L. 26 x w. 13 x h. 25 cm

L. 26 x w. 13 x h. 25 cm

L. 22 x w. 13 x h. 27 cm

L. 19 x w. 13 x h. 25 cm

L.10.5 x diam. 7.5 cm

L.10.5 x diam. 7.5 cm

Hard anodised aluminum

■

■

Fibertech

■

■

■

Machined teeth

■

■

-

-

-

-

Std colour

Red

Red

Yellow

Red

Thread

1.5" BSP F

1.5" NH F

1.5" BSP F

Inlet: 1.5" NH F
Outlet: 1.5" NH M

1.5" NH F

1.5" NH F

OPTIONS AND ACCESSORIES

Stainless steel turbine

□

□

-

-

-

-

Different coloured handles

□

□

-

□

-

-

Multi-expansion foam adapter

●

●

■ Low expansion

-

-

-

Other inlets

□ 2" BSP M

□ 1.5" NPSH F

□ 2" BSP M
□ 1.5" NH F

□ 1.5" NH F
□ 1.5" BSP F

□ 1.5" NPSH F

□ 1.5" NPSH F

International couplings

☎

☎

☎

☎

-

-

WARRANTY

Parts and labour

5 years

5 years

5 years

5 years

2 years

2 years

GAS COOLING NOZZLE

FOR GREATER SAFETY

It is possible to extinguish a fire inside an enclosed space (container, loft, etc.) In the initial stage without the involvement of a firefighting response team.

Very common on merchant vessels to extinguish fires inside containers, gas cooling nozzles are also used in more common operations, where they are inserted into a door, an apartment wall, a roof, a service duct or a false ceiling. They can also be used through a car or truck's engine hood to quickly access a fire.

Technique: Once a hole has been created in the wall of the area on fire using the drilling hammer, the operator can introduce the nozzle inside the area in order to cool and/or directly extinguish the fire.

A battery-powered drill can be a very useful tool when using these nozzles.



REFERENCE	I11.15.003	I11.15.004
PERFORMANCES		
Jet type	Narrow spray	Wide spray
Spray angle	40°	180°
Flow rate (6 bar)	90 l/min	90 l/min
Jet range	10 metres	-
FEATURES (without coupling)		
Material	304 stainless steel	304 stainless steel
Inlet	1" BSP F	1" BSP F
Inlet filter	Ø 2 mm	Ø 2 mm
Length	64 cm	64 cm
Weight	1.3 kg	1.3 kg
VARIANTS		
In 316 stainless steel	☎	☎



DRILL HAMMER:

Essential to create an effective opening to avoid damaging the gas cooling nozzle.

REFERENCE	I11.15.005
Length	50 cm
Weight	2.5 kg
Material	304 stainless steel





ACCESSORIES AND VARIANTS

ESSENTIAL FOR OPTIMISED OPERATIONS

Always listening to firefighters to extend the scope of LEADER FLOW nozzles, our engineers have designed a range of high-performance accessories with specific features which will help you make the difference.



MULTIFLOW 400
with multi-expansion
foam adapter

ACCESSORIES AND OPTIONS



Flush selector ring:

FLOWMATIC COMPACT nozzles can be supplied with an extra ring to select the flush position.



Multi-expansion foam adapters:

LEADER foam adapters have an optimised design to create effective low or medium-expansion foam at all flow rates.



Spinning teeth:

The remarkably strong LEADER FLOW nozzle turbines are made of 316 stainless steel for complete corrosion resistance.



Removable flow limitation:

Used to limit nozzle opening (e.g. to 50%). The firefighter can deliberately unlock the limitation system at any time.



Coloured handle:

For rapid identification on site. 5 colours available for flow handle and pistol grip.



INTERNATIONAL COUPLINGS:

LEADER offers a large range of couplings adapted to standards in various countries.

FOAMJET: LEADER FOAM ADAPTER

To create exceptional quality foam at different flow rates.

Adjustable expansion and reach:

- Long reach with low expansion when the nozzle is set to straight jet.
- Medium expansion and reduced reach when the nozzle is set to wider jet.



FOAMJET MF COMPACT

FOAMJET MF REGULAR

FOAMJET MF LARGE

REFERENCE

LDA-015-II

LDA-013-II

LDA-004-II

PERFORMANCES

Multi-expansion

Low to medium expansion

Low to medium expansion

Low to medium expansion

Max. expansion

≈ 40

≈ 35

≈ 30

FEATURES

weight

1.2 kg

1.25 kg

2.7 kg

material

HDPE

HDPE

Aluminum

Dimensions

L 395 x Ø210 mm

L 395 x Ø210 mm

L 360 x Ø237 mm



TURBINES / SPINNING TEETH



Made of a single piece of stainless steel, they fully meet user expectations. Turbines divide the jet into even finer droplets.

REMOVABLE FLOW RATE LIMITATION



Compatible with FLOWMATIC COMPACT automatic nozzles. Initially developed for the French Air Force, this device - limits the opening of the flow handle. It can be unlocked at any time with simple pressure to allow the user to generate higher flow rates.

FLUSH SELECTOR RING FOR FLOWMATIC COMPACT



FLOWMATIC COMPACT nozzles are provided without a flush selector ring by default. The flush position is accessible by turning the nozzle head beyond the max. protective spray jet. To avoid unintentionally switching to flush, some users prefer that this position is moved to a specific ring, which can be used to select either the flush position or the automatic position. This option extends the nozzle by 2 cm and adds 100 g.

COLOURED HANDLES



To personalise nozzles to make them easier to identify at the end of an operation... LEADER FLOW nozzles have coloured covers (red, blue, yellow, orange, green) for flow reach handles and/or pistol grips.

- FLOWMATIC are delivered as standard with blue covers (except models with a removable flow limitation system).
- MULTIFLOW and ONEFLOW are delivered as standard with red covers.
- TRIGGERFLOW trigger is only available in red.

INTERNATIONAL COUPLINGS



Whether for nozzles or monitors LEADER offers a large range of couplings adapted to standards in various countries:

- GFR, DSP and Guillemin for France and Belgium
- BS336: Instantaneous connection for Great Britain, Indonesia
- Barcelona for Spain
- Storz for Germany, the Netherlands, some countries in Latin America
- Storz Beijin for China.
- Other couplings...



LEADER FLOW MONITORS

OPTIMUM SAFETY FOR
HIGH FLOW RATE OPERATIONS.

For its range of portable monitors, LEADER focuses on safety. The monitor bases have an anti-slip valve and the heads offer a wide protective spray jet.

The safety valve has been studied to avoid fully interrupting the flow rate: it guarantees a sufficient flow to protect the firefighter and significantly reduces water hammer to protect the hoses.



PARTNER 2

P. 32

- ✓ Flow rate up to 3000 lpm / 750 GPM
- ✓ Compact and robust
- ✓ Automatic oscillation



VECTOR 2

P. 36

- ✓ Flow rate up to 5000 lpm / 1250 GPM
- ✓ Versatile
- ✓ Handwheel control



NOZZLES AND ACCESSORIES

P. 40

- ✓ Automatic nozzles
- ✓ Fixed or multi-flow nozzles
- ✓ Vehicle mounting



PARTNER 2

SAFETY AND PERFORMANCE UP TO 3000 L/MIN

A compact design and adapted ergonomics to ensure performance, handling and safety during firefighting!

The PARTNER 2 portable monitor complies with EN15767. It is available with 1 x 2.5", 1 x 4" or 2 x 2.5" inlets.

The large waterway minimises pressure loss and allows a flow rate up to 3000 l/min. The polyester-coated hard anodised aluminum body ensures a long service life.

The oscillating system (optional) made entirely of cast aluminum does not drain water onto the ground; it reinjects the water

needed to operate. The risks of losing stability on soft soil are therefore limited and, in very cold conditions, the risk of firefighters falling on patches of ice are reduced.

PARTNER 2 can be adjusted up to an angle of 85°, which allows it to reach a building window, the top of a pile of containers, a chimney, etc. without needing significant distance.



**PARTNER 2
OSCILLATING**
2 x 2.5" with automatic
nozzle **FLOWMATIC
3000**



PARTNER 2
1 x 2.5" with automatic
nozzle **FLOWMATIC
2000**

FEATURES AND BENEFITS



Up to 3000 l/min:

An ultra-compact monitor with an increased reach due to low pressure loss.

Elevation up to +85°:

To reach elevated fires with little distance.

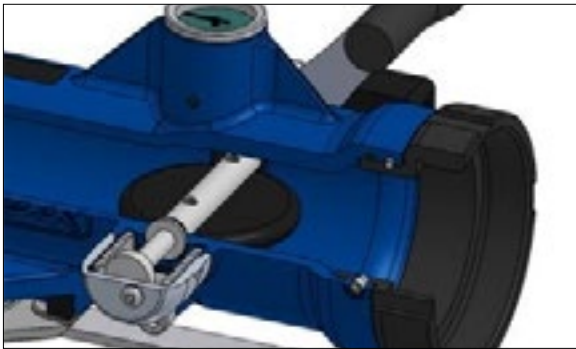

Safety valve:

Anti-slip and anti-lift system which guarantees a minimum flow rate for firefighter safety.

5 flexible legs:

Made of stainless steel equipped with non-slip points in tungsten carbide for improved monitor stability.



Pressure gauge:

Positioned at the monitor inlet, it is well protected against impacts: Equipment always in good condition.

Oscillating system:

With an adjustable range from 20 to 40°, does not drain water onto the ground.

PARTNER 2



**PARTNER 2
1 X 2.5"**

**PARTNER 2
1 X 4" OR 2 X 2.5"**

**PARTNER 2
OSCILLATING
1 X 2.5"**

**PARTNER 2
OSCILLATING
1 X 4" OR 2 X 2.5"**

REFERENCE

CPA-022-OP

CPA-022-8P.

CPA-122-OP

CPA-122-8P

PERFORMANCES

Elevation

25 to 85°

25 to 85°

25 to 85°

25 to 85°

Max. flow rate (l/min.)

3,000

3,000

3,000

3,000

Oscillating system

-

-

■

■

Safety valve

■

■

■

■

FEATURES

(1 x 4" without coupling)

Weight

10.2 kg

10.2 kg

13.8 kg

13.8 kg

Folded dimensions l x w x h (cm)

51 x 24 x 32

51 x 24 x 32

76 x 36 x 36

76 x 36 x 36

Unfolded dimensions l x w x h (cm)

64 x 65 x 32

62 x 65 x 32

72 x 65 x 36

70 x 65 x 36

Hard anodised aluminum body

■

■

■

■

Anti-corrosion polyester coating

■

■

■

■

Large handle

■

■

■

■

304L stainless steel legs

■

■

■

■

Safety strap

■

■

■

■

Protected pressure gauge

■

■

■

■

Horizontal range

+20° L / +20° R

+20° L / +20° R

+20° L / +20° R

+20° L / +20° R

Thread

BSP

BSP

BSP

BSP

Inlet

2.5" F

4" M

2.5" F

4" M

Outlet

2.5" M

2.5" M

2.5" M

2.5" M

VARIANT (GPM AND NH)

Reference

CPA-022-S5

CPA-022-95

CPA-122-S5

CPA-122-95

Max. flow rate

750 GPM

750 GPM

750 GPM

750 GPM

Thread

NH

NH

NH

NH

OPTIONS AND ACCESSORIES

Storage bracket

●

●

●

●

Automatic nozzle

●

●

●

●

Fixed-flow nozzle

●

●

●

●

Selectable flow nozzle

●

●

●

●

2 x 2.5" siamese

-

●

-

●

International couplings

☎

☎

☎

☎

WARRANTY

Parts and labour

5 years

5 years

5 years

5 years

KEY

■ As standard

□ Option (variant) to be indicated when ordering

● Accessory which can be supplied later

- Not applicable

☎ On request





VECTOR 2

SAFETY AND PERFORMANCE UP TO 5000 L/MIN

The VECTOR 2 monitor is a portable and transformable monitor made up of a base and a quick connect turret. The base has a safety valve, a large handle and a protected pressure gauge.

The turret, with a drain valve at the bottom of the monitor, is also equipped with a large transport handle and two wheels to adjust and automatically lock rotation and elevation.

The design of the VECTOR 2 allows a large waterway which minimises pressure losses. The shape of the specific pipework gives it a very low centre of gravity. With flexible legs in stainless steel with tungsten carbide points, the VECTOR 2 monitor offers excellent stability, even on a smooth surface.

The VECTOR turret disconnects very quickly from its base. It can be snapped into a threaded truck mount with or without flanges to create a fixed monitor on the roof of a vehicle or on site in an at-risk industry.



VECTOR 2
1 x 4"
with automatic nozzle
FLOWMATIC 3000



VECTOR 2
2 x 2.5"
with automatic nozzle
FLOWMATIC 3000

FEATURES AND BENEFITS



Up to 5000 l/min:

Maximum range thanks to low pressure losses.



Wheel-adjustable rotation and elevation:

Natural and automatic position lock.

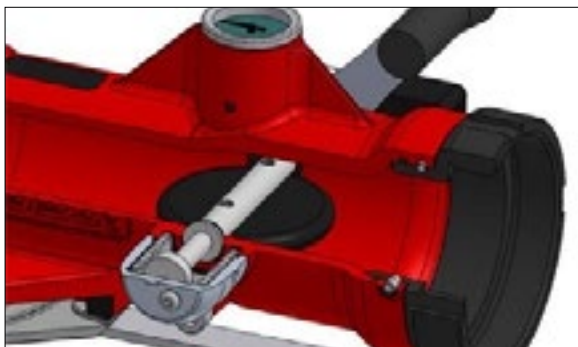

Safety valve:

Anti-slip and anti-lift system which guarantees a minimum flow rate for firefighter safety.



4 flexible legs and 5 stabilisation points:

In stainless steel equipped with non-slip points in tungsten carbide for improved monitor stability.



Protected pressure gauge:

Positioned in the monitor body, it is well protected against impacts. Equipment always in good condition.



Safety override:

Option to disable the safety valve without limiting the monitor flow rate.

VECTOR 2



VECTOR 2 TURRET

**VECTOR 2 BASE
1 X 4"**

**VECTOR 2 BASE
2 X 2.5"**

REFERENCE

CPA-022-OP

CPA-022-8P.

CPA-122-OP

PERFORMANCES

Elevation

-50° to + 90°

-

-

Max. flow rate

5000 l/min

5000 l/min

5000 l/min

Wheel for elevation

■

-

-

Safety valve

-

■

■

FEATURES (without coupling)

Weight

11.3 kg

8.7 kg

11.4 kg

Folded dimensions l x w x h

38 x 47 x 31 cm

51 x 20 x 22 cm

64 x 24 x 25 cm

Monitor unfolded dimensions l x w x h

-

65 x 65 x 52 cm

87 x 65 x 52 cm

Hard anodised aluminum body

■

■

■

Anti-corrosion polyester coating

■

■

■

Large carry handle

■

■

■

Automatic drain valve

■

-

-

304 L stainless steel legs

-

■

■

Horizontal range

120° L / 80° R

-

-

Removable elevation lock at 25°

■

-

-

Safety strap

-

■

■

Protected gauge

-

■

■

Thread

BSP

BSP

BSP

Inlet

-

4" M

2 x 2.5" F

Outlet

2.5" M

-

-

VARIANT (GPM & NH)

Reference

CPA-310-I5

CPA-210-9I

CPA-210-SI

Max. flow rate

1250 GPM

1250 GPM

1250 GPM

Thread

NH

NH

NH

OPTIONS AND ACCESSORIES

Automatic nozzle

●

-

-

Fixed-flow nozzle

●

-

-

Multi-flow nozzle

●

-

-

International couplings

☎

☎

☎

WARRANTY

Parts and labour

5 years

5 years

5 years

KEY

■ As standard

□ Option (variant) to be indicated when ordering

● Option which can be supplied later

- Not applicable

☎ On request





NOZZLES AND ACCESSORIES

ESSENTIAL FOR SUCCESSFUL OPERATIONS

In order to extend the scope of LEADER FLOW monitors, our engineers have designed a range of high-performance accessories with specific features which will help you make the difference.

LEADER has chosen to use high-quality materials to ensure excellent durability:

- Monitor heads in:
 - hard anodised aluminum
 - with polyurethane bumper for FLOWMATIC and MULTIFLOW.
- Stainless steel storage holder.
- Engraved markers which are more resistant than labels.
- Stainless steel screws.



FEATURES AND BENEFITS



Vector turret adapter:

Used to connect a VECTOR 2 turret directly to a pipe or screw-in flange.



Very wide spray jet:

To create a wide water curtain and ensure maximum protection.



Automatic nozzles:

The FLOWMATIC 2000, 3000 and 5000 offer optimised flow rate and reach.



Fixed-flow nozzles:

The ONEFLOW 1300, 2000 and 3000 are made entirely of hard anodised aluminum for increased resistance.



Selectable nozzle:

MULTIFLOW 3000 is used to select the desired flow rate between 500 and 3000 l/min with 500 l/min increments.



Polyurethane bumper:

On the FLOWMATIC and MULTIFLOW, polyurethane offers much better resistance to hydrocarbons than rubber.

MONITOR NOZZLES

Made of hard anodised aluminum alloy with a very wide protective spray jet.

3 types:

- Fixed-flow: ONEFLOW
- Selectable flow: MULTIFLOW
- Automatic: FLOWMATIC



	ONEFLOW 1300	ONEFLOW 2000	ONEFLOW 3000	MULTIFLOW 3000	FLOWMATIC 2000	FLOWMATIC 3000	FLOWMATIC 5000
REFERENCE	CDA-025-OI	CDA-023-OI	CDA-024-OI	CDA-040-OI	CDA-020-OI	CDA-021-OI	CDA-035-OI
PERFORMANCES							
Fixed flow rate	■	■	■	-	-	-	-
Selectable flow	-	-	-	■	-	-	-
Automatic	-	-	-	-	■	■	■
Flow rates l/min @ 6 bar	1300	2000	3000	500 / 1000 / 1500 / 2000 / 2500 / 3000	500 - 2000	1500 - 3000	1700 - 5000
FEATURES (without coupling)							
Weight	1.8 kg	1.8 kg	3.2 kg	3.8 kg	3.6 kg	3.6 kg	6 kg
Dimensions (cm)	diam, 12 x 17	diam, 12 x 17	diam, 15 x 22	diam, 15 x 27	diam, 15 x 23	diam, 15 x 23	diam, 18 x 29
Bumper material	aluminum	aluminum	aluminum	polyurethane	polyurethane	polyurethane	polyurethane
Std inlet	2.5" BSP F	2.5" BSP F	2.5" BSP F	2.5" BSP F	2.5" BSP F	2.5" BSP F	2.5" BSP F
VARIANTS (IN GPM AND NH)							
Reference	CDA-026-SI	CDA-027-SI	CDA-028-SI	CDA-041-SI	CDA-020-SI	CDA-022-SI	CDA-036-SI
Flow rates gpm @ 100 psi	350	500	750	125 / 250 / 375 / 500 / 625 / 750	500	750	1250
Thread	2.5" NH F	2.5" NH F	2.5" NH F	2.5" NH F	2.5" NH F	2.5" NH F	2.5" NH F
WARRANTY							
Parts and labour	5 years	5 years	5 years	5 years	5 years	5 years	5 years

SIAMESE

Made of aluminum alloy, this siamese with clapper is used to transform the 4" inlet of the PARTNER 2 into a monitor with 2 x 2.5" swivel inlets.

MODEL	2 x DSP65 -> 1 x 4" BSP F	2 x 2.5" BSP F -> 1 x 4" BSP F
REFERENCE	I18.20.035	I18.20.036
Dimensions (Length x width)	24 x 32 cm	18 x 24 cm
Weight (kg)	3.1 kg	2.3 kg



FOAM TUBE

LEADER offers a wide range of foam tubes in light alloy, short or long, standard or self-inducing.
All the models offer excellent performance features allowing long jets of foam or water.
Option: adjustable concentration at 3 or 6%.

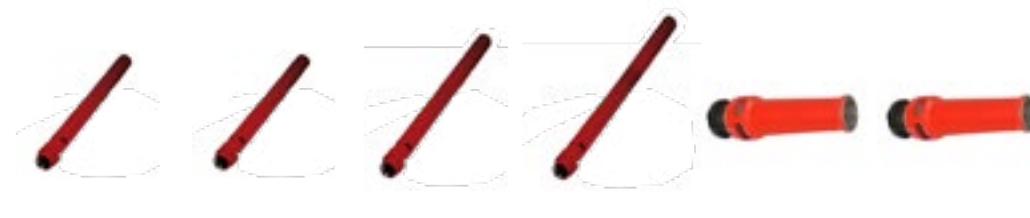

	1500	2000	3000	4000	2000 SHORT	3000 SHORT
REFERENCE	112.43.000	112.43.001	112.43.002	112.43.003	CDA-030-OI	CDA-031-OI
PERFORMANCES						
Expansion	6 - 7	6 - 7	6 - 7	6 - 7	<10	<10
Range	≈39m	≈45m	≈55m	≈62m	≈50m	≈55m
Flow rates @ 7 bar	1500 l/min	2000 l/min	3000 l/min	4000 l/min	2000 l/min	3000 l/min

FEATURES (without coupling)

Weight (kg)	4 kg	4.4 kg	6.1 kg	6.5 kg	3.6 kg	3.6 kg
Length (cm)	101	101	118	133	45	45
Std inlet	2.5" BSP F	2.5" BSP F	2.5" BSP F	2.5" BSP F	2.5" BSP F	2.5" BSP F

VARIANTS

Self-inducing model	<input type="checkbox"/>	<input type="checkbox"/>	<input type="checkbox"/>	<input type="checkbox"/>	<input type="checkbox"/>	<input type="checkbox"/>
Available in stainless steel	<input type="checkbox"/>	<input type="checkbox"/>	<input type="checkbox"/>	<input type="checkbox"/>	-	-

ADAPTER FOR VEHICLES AND FIXED INSTALLATION

Male 4" threaded and female 3" tapped, the adapter for the VECTOR 2 turret can be fastened directly to a pipe or a screw-in flange. Lightweight (in aluminum alloy), it also allows the VECTOR turret to be mounted on a vehicle.

MODEL	4" NPT M / 3" NPT F	4" BSP M / 3" BSP F
REFERENCE	CPA-400-10I	CPA-400-8I
Dimensions	114 x 215 mm	114 x 215 mm
Weight (kg)	2.2	2.2



STORAGE BRACKET

Made of stainless steel, the storage bracket for the PARTNER 2 is used to store the monitor in a truck cabinet.

REFERENCE	CPA-200-II
Dimensions	5 x 20 x 49 cm
Weight (kg)	3.1





OVERVIEW OF NOZZLE BY TYPE AND FLOW RATE

L/min	0	20	40	50	70	80	90	100	125	150	200	235	250	300	400	500			1000	page															
GPM	0	5	10				24		30	40	50	60			95	125	150	200	250																
SELECTABLE FLOW	Compact MULTIFLOW / 20-40-100-150 lpm																										p20								
	Compact MULTIFLOW / 5-10-24-40 gpm																						p21												
	Compact MULTIFLOW / 40-100-150-235 lpm																										p22								
	Compact MULTIFLOW / 10-24-40-60 gpm																							p23											
	Compact MULTIFLOW / 70-130-230-400 lpm																										p24								
	Regular MULTIFLOW / 70-130-230-400 lpm																										p25								
	Regular MULTIFLOW / 100-250-350-500 lpm																											p26							
	Compact MULTIFLOW / 30-60-95-125 gpm																								p27										
	Regular MULTIFLOW / 60-95-125-150 gpm																											p28							
	Large MULTIFLOW / 95-125-150-200 gpm																													p29					
	Large MULTIFLOW / 300-500-750-1000 lpm																														p30				
Large MULTIFLOW / 125-150-200-250 gpm																															p31				
AUTOMATIC	Compact FLOWMATIC / 150 lpm																						p33												
	Compact FLOWMATIC / 250 lpm																											p34							
	Compact FLOWMATIC / 400 lpm																											p35							
	Regular FLOWMATIC / 400 lpm																												p36						
	Compact FLOWMATIC / 125 gpm																														p37				
	Regular FLOWMATIC / 500 lpm																															p38			
	Large FLOWMATIC / 200 gpm																															p39			
Large FLOWMATIC / 250 gpm																																p40			
Large FLOWMATIC / 1000 lpm																																	p41		
OTHER NOZZLES	TWINACTION																														p43				
	GAS COOLING																																	p44	
	ONE-FLOW																																	p45	
	SMOOTH BORE																																		



OVERVIEW OF MONITORS

L/min	0	500	1000	1500	2000	2500	3000	3500	4000	4500	5000	page
GPM	0	125	250	350	500	625	750	875	1000	1125	1250	
MONITORS	PARTNER 1 x 2.5"											p20
	PARTNER 1 x 4"											p21
	PARTNER 2 x 2.5"											p22
	VECTOR 1 x 4"											p24
	VECTOR 2 x 2.5"											p25
	VECTOR 2 x 2.5" *											p26
NOZZLES fixed and selectable flow			ONE-FLOW 1500									p28
			ONE-FLOW 350G									p29
				ONE-FLOW 2000								p30
				ONE-FLOW 500G								p31
							ONE-FLOW 3000					p32
							ONE-FLOW 750G					p33
		MULTIFLOW 3000										p34
		MULTIFLOW 750G										p35
NOZZLES Automatic	FLOWMATIC 2000											p36
	FLOWMATIC 500G											p37
	FLOWMATIC 3000											p38
	FLOWMATIC 750G											p39
	FLOWMATIC 5000											p40
	FLOWMATIC 1250G											p41

* supplied with two 4" lines

LEADER®

● *Fighting for performance*

SINCE 1985, LEADER HAS DESIGNED AND MANUFACTURED HIGHER PERFORMING EQUIPMENT USED IN FIREFIGHTING, FIRE TRAINING AND SEARCH AND RESCUE APPLICATIONS AND PROPOSES THEM TO FIRE & RESCUE SERVICES, CIVIL DEFENSE, HAZARDOUS INDUSTRIES, NGOS, MARITIME SERVICES, ETC. ON THE 5 CONTINENTS.



A MAJOR AXIS: INNOVATION

To meet the advancing challenges of fire hazards and search & rescue missions, equipment must continually evolve and adapt to be more effective while ensuring maximum safety for workers.

To meet these challenges, LEADER is committed to constant innovation and new technologies and has its own in-house Research & Development team which works alongside end-users to design and develop the equipment that will be available tomorrow.

To test our equipment and assess its performance, we at LEADER continually invest in our own infrastructure:

- ▶ Water and High-Expansion Foam test room (400 sq m)
- ▶ Ventilation test room (400 sq m)
- ▶ Fire test area in fire container - Fire extinguishing equipment
- ▶ Casualty Search Equipment test area

OUR COMMITMENT

When you choose LEADER equipment, you are assured of the quality and compliance of our products. These have been made in our workshops by our engineering and electronics specialists.

ISO 9001 certified since 1999, LEADER:

- ▶ Carries out checks at every stage of the manufacturing process as well as on the finished products before dispatch,
- ▶ Provides continuous training for all its staff.

GUARANTEED EQUIPMENT

Every LEADER product comes with a specific contractual guarantee.

CLOSE TO OUR CUSTOMERS

Through its sales force, its subsidiaries (in Germany, Austria, China and the USA) and an international distribution network, LEADER is present worldwide, keeping us as close as possible to its customers.



ADAPTED TRAINING

For optimal and long-term use of the equipment you purchase, LEADER can propose suitable training on the handling, on the use and maintenance of the equipment. Training can be done at our site or at your own site.

AN INTERNATIONAL PRESENCE

SUBSIDIARIES AND A STRONG RETAILER NETWORK

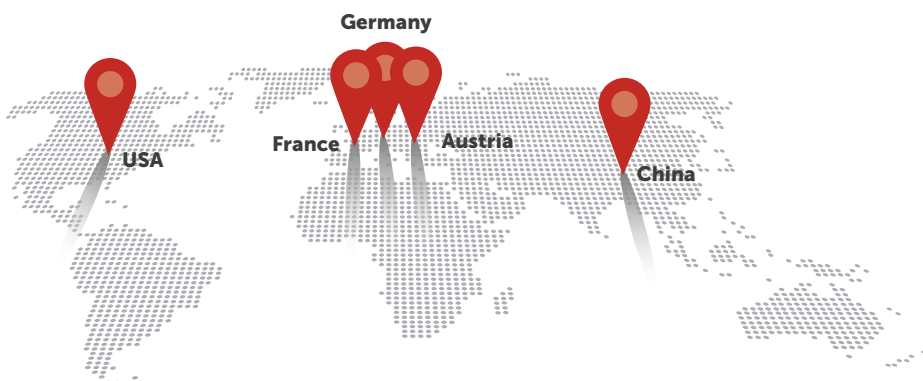

LEADER GROUP



MOBILE VENTILATION



LARGE-FLOW VENTILATION



THERMAL VISION



FIRE EXTINGUISHING



FIRE TRAINING DEVICES



SEARCH AND RESCUE EQUIPMENT



CHAINSAWS



FIRE FOAM CONCENTRATES

LEADER®

LEADER GROUP S.A.S - FRANCE

ZI des Hautes-Vallées - Chemin n° 34 - CS20014 - 76930 Octeville sur Mer - France
Tel.: +33 (0)2.35.53.05.75 - Fax: +33 (0)2.35.53.16.32
info@leader-group.eu
www.leader-group.company

LEADER GMBH - GERMANY

Zur Fabrik 10 - 66271 Kleinblittersdorf - Germany
Tel.: +49 (0) 6805/60067-0 - Fax: +49 (0) 6805/60067-10
info@leader-gmbh.de
www.leader-group.company/de

LEADER PHOTONICS - AUSTRIA

Tirolerstrasse 80 - 9500 Villach - Austria
Tel.: +43-(0)4242 58030 21
office@leader-photonics.com
www.leader-photonics.com

LEADER CHINA - CHINA

Room 706, No 23, Lane 466, YinDu Road, Minhang District, Shanghai - P.R.China - China
Tel.: +86 136 36 55 57 54
www.leader-group.company

TEMPEST

TEMPEST TECHNOLOGY - USA

4708 N. Blythe Avenue - Fresno - California 93722 - USA
Tel.: +1 559-277-7577 - Fax: +1 559-277-7579
response@tempest.us.com
www.tempest.us.com

BIOEX®

BIOEX S.A.S - FRANCE

5, chemin de Clape-Loup - 69280 - Sainte-Consoce - France
Tel.: +33 (0)4 74 70 23 81 - Fax: 33 (0)4 74 70 23 94
contact@bio-ex.fr
www.bio-ex.com

BIOEX GMBH - GERMANY

Zur Fabrik 10 - 66271 Kleinblittersdorf - Germany
Tel.: +49 (0) 6805/60067-0 - Fax: +49 (0) 6805/60067-10
info@leader-gmbh.de
www.bio-ex.com/de

